

A simple multiple keying interface for the Elecraft K2 by Paul Evans, W4/VP9KF.

Combining the keying from different sources is a little tricky when using the Elecraft K2 because of the detection of paddle keying or straight keying modes. This can easily be overcome by using this circuit. In fact, it was squeezed into the 3.5mm stereo connector itself and the DB-9 connector shell, so there is no requirement for an external board or box.

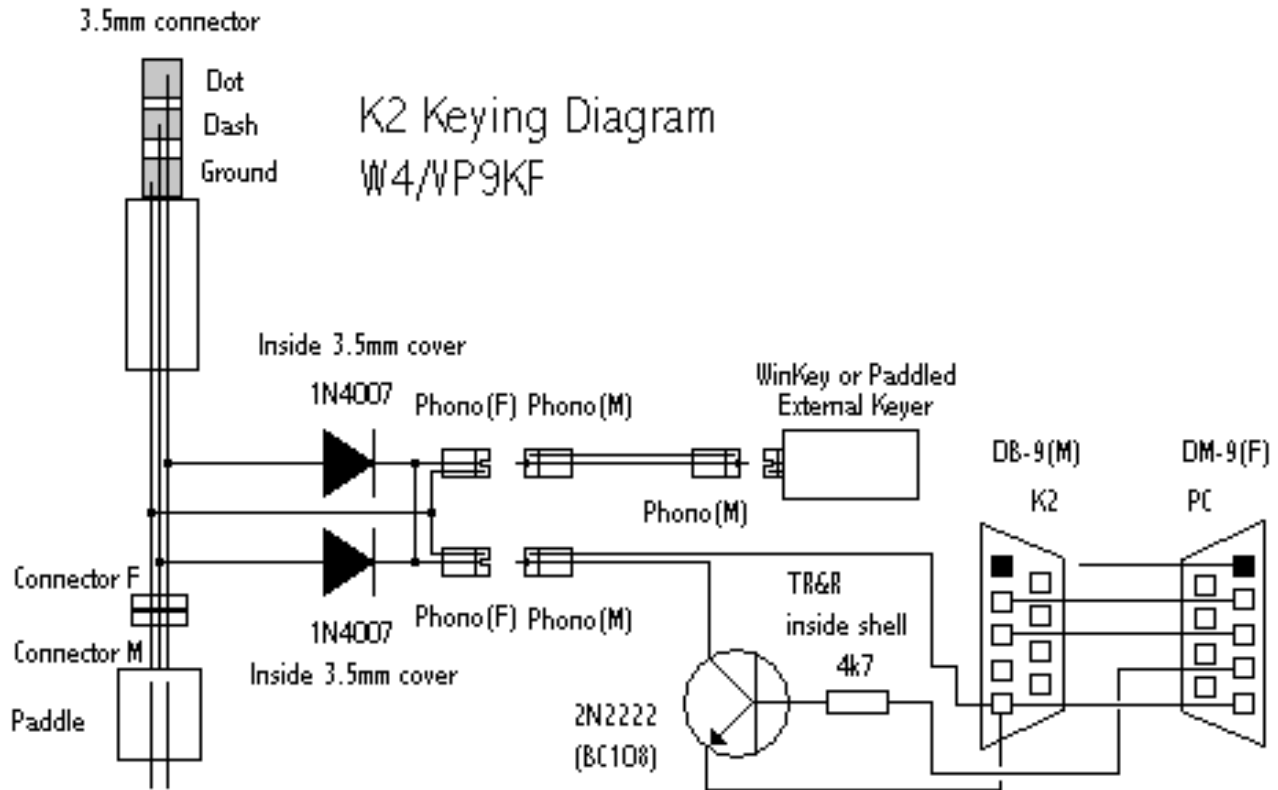

USA translation: Phono = 'RCA connector'



Please note: This circuit is open-hardware. Do not change these notes or remove reference to the design source. You may link to it, but do not copy to other servers or group files.